

4

3

2

1

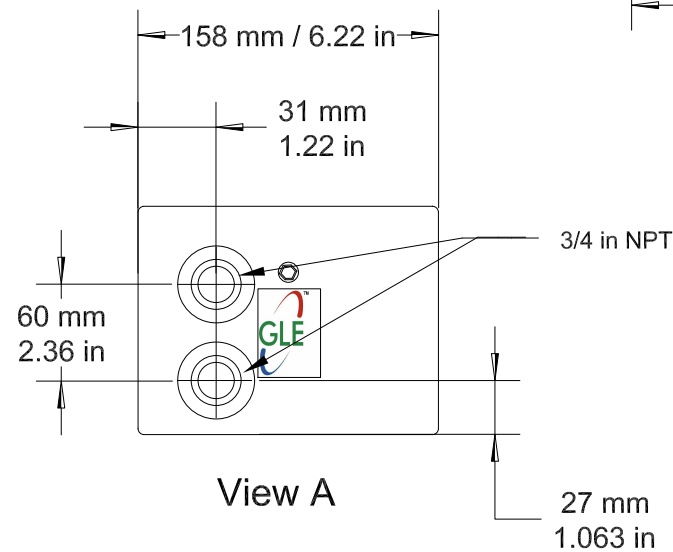
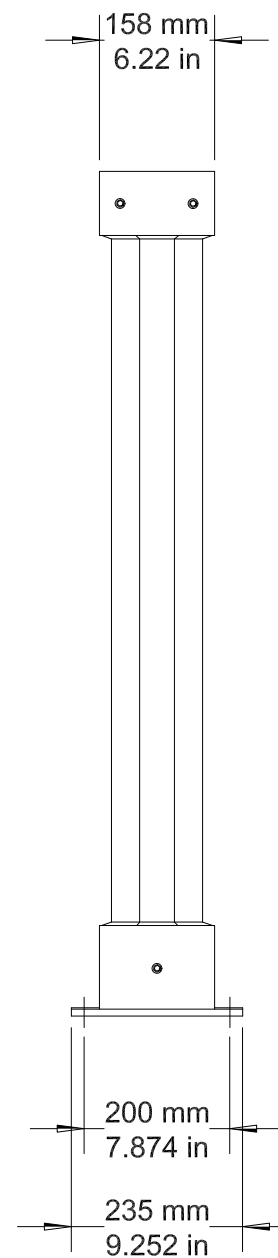
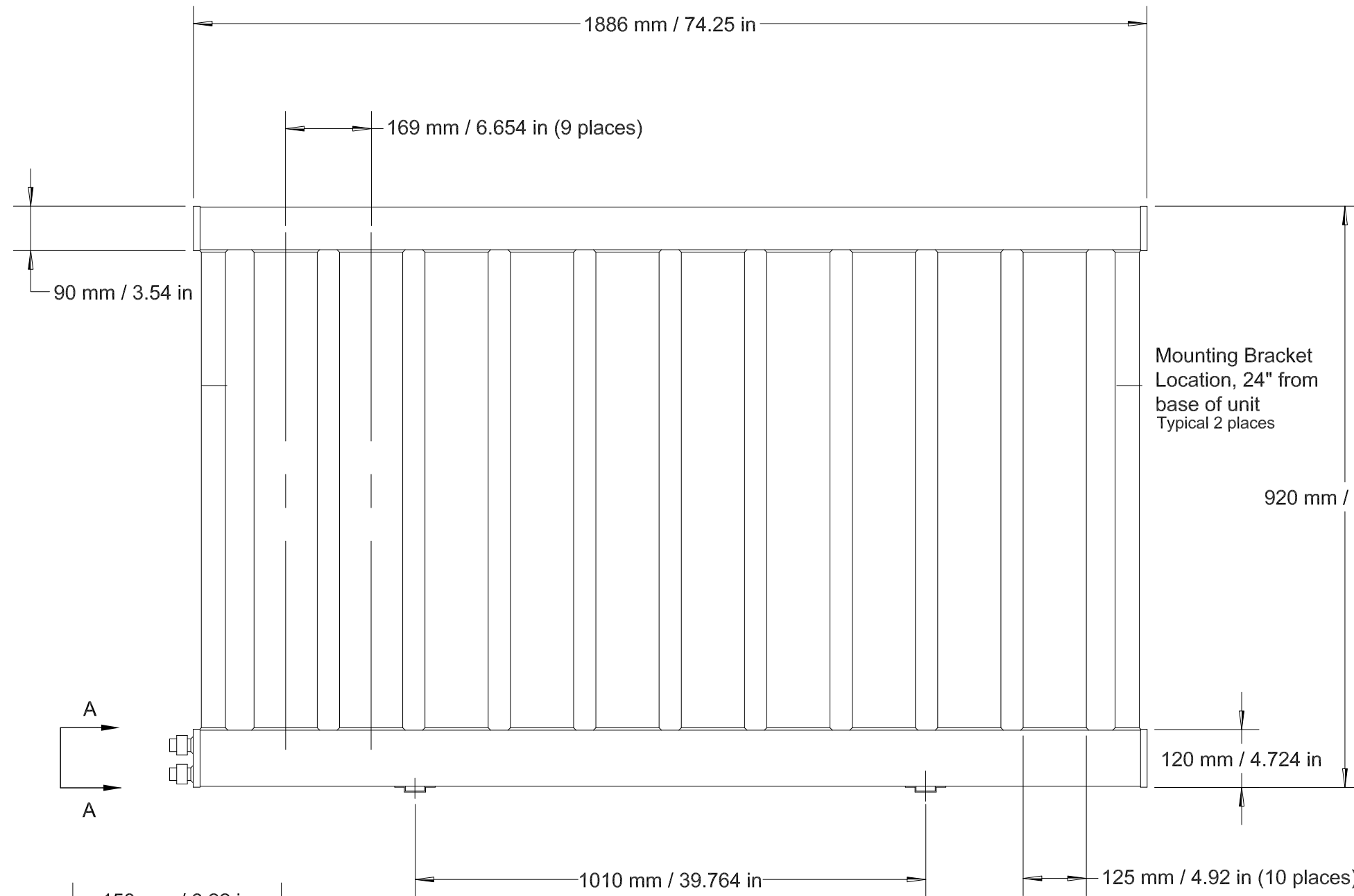

- Notes:
1. Unit designed for potable water applications.
 2. Unit to be installed following GLE installation guide.
 3. Drain and cover unit when not in use to prevent possible damage.

THIS DRAWING IS THE PROPERTY OF GREAT LAKES ELECTRIC, LLC. IT CONTAINS CONFIDENTIAL INFORMATION BELONGING TO AND/OR ENTRUSTED TO GREAT LAKES ELECTRIC. IT IS DISCLOSED IN CONFIDENCE AND SHALL NOT BE HELD, REPRODUCED, DISCLOSED OR USED EXCEPT IN A MANNER AND FOR A PURPOSE EXPRESSLY PERMITTED BY GREAT LAKES ELECTRIC IN WRITING.

VENDORS SHALL NOT REVISE ANY PHYSICAL, DIMENSIONAL, OR PERFORMANCE CHARACTERISTICS UNLESS AUTHORIZED IN WRITING BY GREAT LAKES ELECTRIC.

GREAT LAKES ELECTRIC TEST SPECIFICATIONS, IF ANY, ARE NOT INTENDED TO ASSUME ANY RESPONSIBILITY FOR SUBSEQUENT PROBLEMS WITH OR CAUSED BY THE PART, COMPONENT, OR ASSEMBLY PROVIDED BY THE SUPPLIER AND DO NOT RELIEVE THE SUPPLIER OF ITS OBLIGATIONS

INCLUDING, BUT NOT LIMITED TO, THE NEED TO PERFORM ITS OWN TESTING, INSPECTION AND ONGOING QUALITY CONTROL, AND ASSURING FITNESS FOR USE. ANY GREAT LAKES ELECTRIC RECOMMENDED TEST AND ITS OUTCOME DO NOT IN ANYWAY LIMIT OR CHANGE THE WARRANTY CONTAINED IN GREAT LAKES ELECTRIC'S PURCHASE ORDER OR SUPPLY AGREEMENT.
INTERPRETATION PER ASME Y14.5W-1994



Great Lakes Electric - Solar Energy Division
1776 Hilltop Road, St. Joseph, MI 49085

TITLE			
SHP310 Assembly Drawing			
SIZE	CAGE CODE	DWG NO	REV
B		SHP310-E-00-A	0
SCALE	SHEET		
None	1 of 1		

4

3

2

1