



# GLE SOLAR POOL HEATING SYSTEM INSTALLATION MANUAL

GLE SOLAR



Document maintained by: GLE Solar

1776 Hilltop Road  
Saint Joseph, MI 49085

Phone: (269) 408-8276  
Website: <http://www.glesolar.com>

# List of Contents

<b>1.0 PREFACE .....</b>	<b>4</b>
<b>2.0 PRODUCT OVERVIEW .....</b>	<b>5</b>
<b>2.1 PRODUCT DESCRIPTION .....</b>	<b>5</b>
<b>2.2 WARNINGS AND PRECAUTIONS .....</b>	<b>6</b>
<b>3.0 PREPARATIONS PRIOR TO INSTALLATION .....</b>	<b>7</b>
<b>3.1 PANEL INSTALLATION OVERVIEW .....</b>	<b>8</b>
<b>3.2 CONSULTING LOCAL AUTHORITIES.....</b>	<b>9</b>
<b>3.3 COLLECTOR PANEL ORIENTATION.....</b>	<b>10</b>
<b>3.4 COLLECTOR SITE SELECTION.....</b>	<b>10</b>
<b>3.5 COLLECTOR SIZING DETERMINATION.....</b>	<b>11</b>
<b>3.6 HOW MANY PANELS TO USE.....</b>	<b>14</b>
<b>4.0 PANEL MOUNTING CONFIGURATIONS .....</b>	<b>15</b>
<b>4.1 SINGLE PANEL .....</b>	<b>15</b>
<b>4.2 MULTIPLE PANELS .....</b>	<b>15</b>
<b>4.3 COMMERCIAL ARRAY PANEL LAYOUT.....</b>	<b>17</b>
<b>5.0 COLLECTOR PANEL INSTALLATION .....</b>	<b>18</b>
<b>5.1 UNPACKING COLLECTOR MAIN ASSEMBLY .....</b>	<b>18</b>
<b>5.2 GROUND INSTALLATION.....</b>	<b>19</b>
<b>6.0 POOL HEATING SYSTEM DESIGN .....</b>	<b>21</b>
<b>6.1 BASIC SYSTEM DETAILS .....</b>	<b>22</b>
<b>6.2 PIPE MATERIALS AND INSTALLATION.....</b>	<b>23</b>
<b>6.3 COMPONENT LOCATIONS AND DETAILS .....</b>	<b>24</b>
<b>7.0 POOL SYSTEM OPERATION .....</b>	<b>25</b>
<b>7.1 GENERAL OPERATION AND SYSTEM STARTUP .....</b>	<b>25</b>
<b>7.2 SETTING PARAMETERS .....</b>	<b>26</b>
<b>7.3 SYSTEM FILLING.....</b>	<b>26</b>

List of Content

---

<b>8.0 GLASS TUBE INSTALLATION .....</b>	<b>29</b>
<b>8.1 UNPACK GLASS COLLECTOR TUBES.....</b>	<b>29</b>
<b>8.2 INDIVIDUAL PLACEMENT OF TUBES.....</b>	<b>29</b>
<b>8.3 COMPLETION OF INSTALLATION .....</b>	<b>29</b>
<b>9.0 MAINTENANCE AND PRECAUTIONS .....</b>	<b>30</b>
<b>9.1 MAINTENANCE.....</b>	<b>30</b>
<b>9.2 SPECIAL CONSIDERATIONS .....</b>	<b>31</b>
<b>9.3 SYSTEM SHUTDOWN .....</b>	<b>32</b>

## Chapter 1.0 Preface

 THE FOLLOWING DOCUMENT MUST BE READ IN ITS ENTIRETY BEFORE STARTING THE INSTALLATION PROCESS. THESE INSTRUCTIONS MUST ALSO BE MADE AVAILABLE AT THE INSTALLATION SITE.

 PRIOR TO INSTALLATION, CHECK FOR UPDATES AT:  
[www.glesolar.com/media/downloads](http://www.glesolar.com/media/downloads)

## Chapter 2.0 Product Overview

If this is your first installation using GLE Solar evacuated tube batch collectors, read Sections 2.1 and 2.2 carefully and in their entirety. Experienced professionals in the solar thermal market will note that these collectors are significantly different than any other solar thermal collectors available. The distinctions between GLE Solar evacuated tube batch collectors and traditional solar thermal collectors (flat plate, standard evacuated tube collectors, and conventional integrated collector-storage units) necessitate the specific installation details provided in this manual.



**DO NOT substitute GLE Solar collectors into a system layout designed for different collectors.**



**DO NOT attempt to plumb these collectors into a thermosyphon or drainback configuration.**

### 2.1 Product Description

As the product name suggests, the GLE Solar evacuated tube batch collector is essentially a hybrid of two common solar thermal technologies: the evacuated tube collector (ETC) and the integrated collector-storage unit (ICS). Standard ETCs use a series of thin evacuated tubes with heat pipes at their core and constantly cycle water through a header manifold where all of the heat pipes meet. ICS units, in their simplest form, are just sizeable water tanks left outdoors to absorb solar energy for gradual batch heating.

The evacuated tube batch collector unites the fluid volume benefits of an ICS with the thermal insulation of an ETC. An evacuated tube batch collector consists of 9 or 10 cylindrical reservoirs, each capable of storing something between 2 and 5 gallons, depending on the specific model. The reservoirs in a single collector are connected in series, forming a serpentine array for large volume storage. An internal return pipe extends near the top of each reservoir, so when the fluid flows, the warmest water in each reservoir is forced to the bottom of the next reservoir in series. During installation, each reservoir is fitted with an evacuated glass tube shell. The glass encasement contains a vacuum layer between two glass surfaces, so it acts in a thermal insulation role similar to that of a thermos.

This design offers several critical benefits. The large capacity allows for substantial energy collection without the need for flow, unlike typical ETCs. In fact, the simplest domestic hot water systems involving evacuated tube batch collectors don't require a pump at all. Other systems do utilize a pump, but it runs for a fraction of the time compared with ETC systems. The disjointed series of reservoirs offers more surface area for solar absorption than any standard ICS, and the reservoirs are still narrow enough to accommodate the insulating evacuated tube encasements. Ultimately, the evacuated tube batch collector simultaneously offers the benefits of ETC and ICS technologies, but the unique flow path also requires novel system design characteristics distinct from those predecessors.

### 2.2 Warnings and Precautions

 **FOLLOW DIRECTIONS:** Installation and operation of this solar water heating system must always be in accordance with this manual. If the installation deviates from the description provided in this document, the warranty with GLE Solar will be void. If the system is used in a manner that deviates from the description provided in this document, the warranty will be void and the operator risks personal injury or property damage at operator's own liability.

 **TOOLS & PERSONNEL:** The packaged collector may weigh as much as 250 pounds prior to installation. Be certain to bring the appropriate equipment and personnel to the job site to handle the collector, in order to reduce risk of damage or injury. Always wear appropriate safety equipment during installation or maintenance of unit, such as safety glasses and protective gloves.

 **SAFETY CONSIDERATIONS:** After removing the packaging, always handle the collector by the steel end posts; NEVER lift the collector by the top or bottom rail or the stainless steel reservoirs. Do not store or place combustible materials on or near the solar water heating system.

 **HANDLING GLASS TUBES:** Do not remove the evacuated glass tubes from their packaging until immediately before executing the corresponding step in this manual. If exposed to sunlight for too long before installation, the inner surface could become extremely hot. Use caution when handling evacuated glass tubes and follow installation documentation explicitly. Though durable, evacuated tubes are glass and will break if dropped or hit with force, so handle with care.

 **CODE COMPLIANCE:** Units must be installed in compliance with all federal, state, and local Mechanical and Plumbing Code Standards.

 **NOTE:** Any act to cover or obstruct the collector in any way will reduce the performance output to some degree.

## Chapter 3.0 Preparations Prior to Installation

### 3.1 Panel Installation Overview

This picture shows an actual collector panel installed in the field. The collector main assembly consists of the assembly top rail (1), the assembly bottom rail (2), the two assembly support posts (3), and stainless steel reservoirs extending upward from the bottom rail (not pictured, because the glass tubes cover the reservoirs). The evacuated glass tubes (6) ship with the collector panel in separate packaging. The mounting brackets (5) can be supplied by GLE Solar or obtained elsewhere. Mounting posts (4) should consist of 4"x4" pieces of lumber cut to the appropriate height.

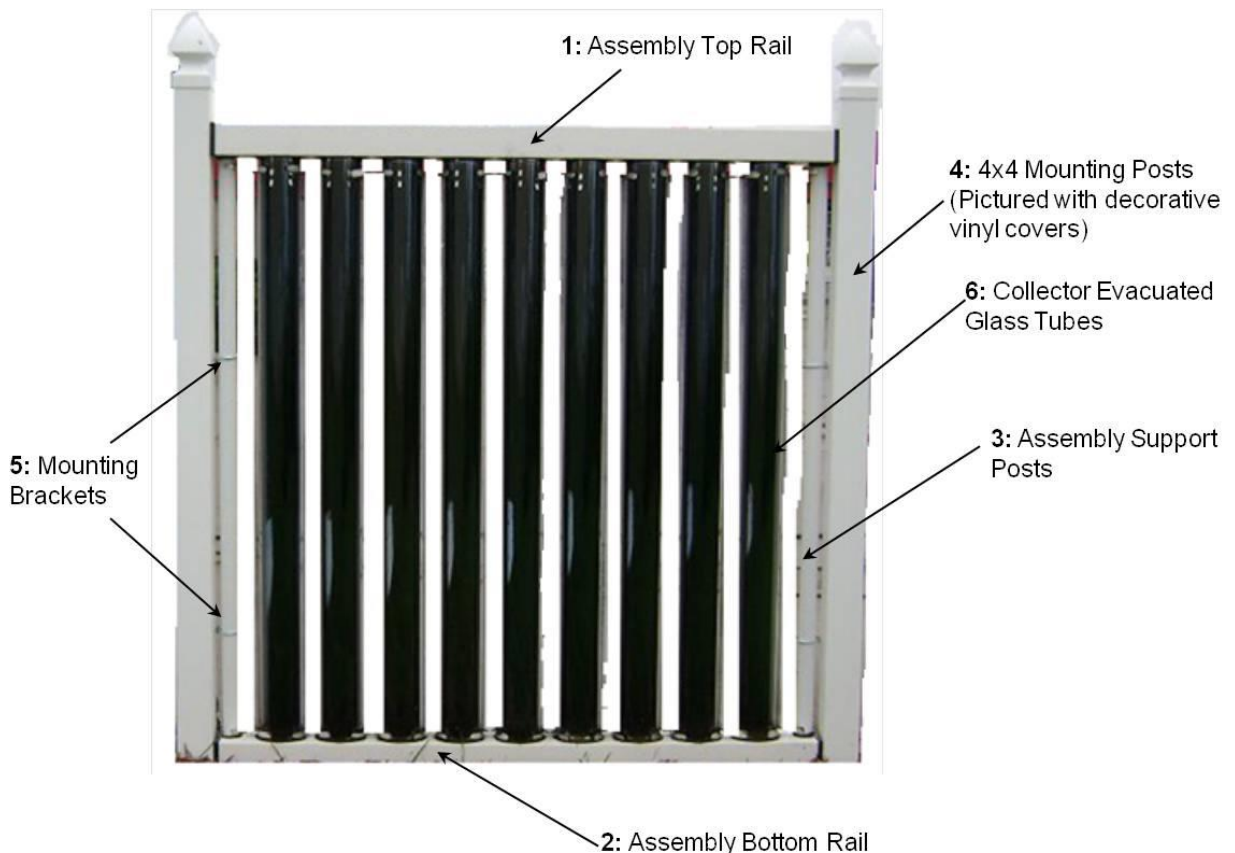

Figure 3.1: Collector installation overview showing key elements of system installation.



### 3.0 Preparation prior to installation

---

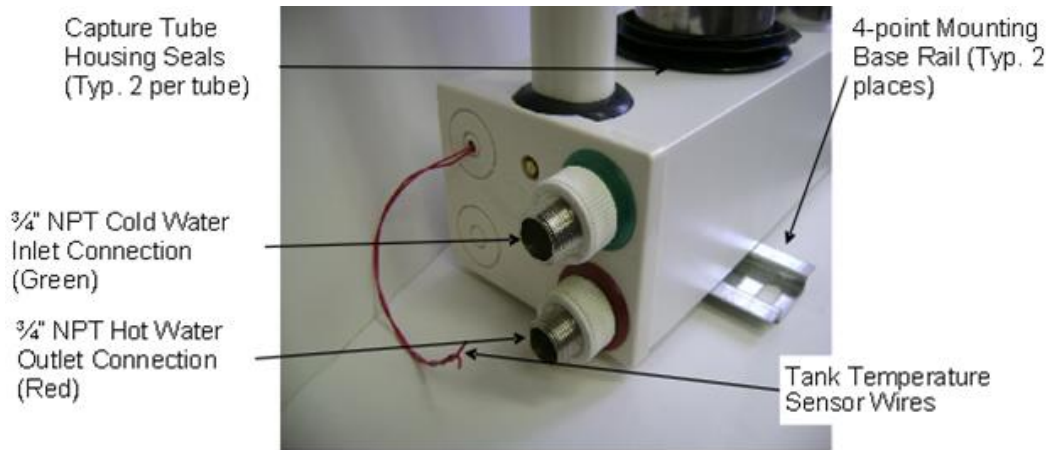

Figure 3.2: Installation interface offering a view of the plumbing inlet and outlet, the thermistor sensor wire, and the base rail feet.

## 3.2 Consulting Local Authorities

**Utility Markers:** Before beginning, always contact the local utility companies to mark the location of any preexisting underground utilities. This will rule out certain potential installation locations before proceeding too far or possibly causing collateral damage.

**Permit:** Prior to installation, consult with the appropriate municipal authorities to determine if this installation project will require a permit. If a permit is required before building can begin, adjust the installation timeframe accordingly.

### 3.3 Collector Panel Orientation

3.3.1 For optimal results, plan to position the collector panels in the corresponding direction for each of the following applications:

- Pool heat: Running North-South (surfaces facing East and West).
- Radiant heat: Running East-West (surfaces facing North and South)
- Domestic Hot Water: Running North-South preferred, running East-West optional.

3.3.2 The unit should be positioned in a location with a minimum of 6 hours of direct sun exposure. A Solar Pathfinder or similar tool can help evaluate the available solar resource at an installation site.

3.3.3 If the unit is placed in a location with heavy shade or fewer than 6 hours of direct sun exposure, the unit will underperform through no fault of the manufacturer. GLE will not be liable for disappointing results attained from a fully-functional unit that is poorly positioned during installation.

3.3.4 If the collector is running North-South, prioritize the solar exposure of the West face of the collector over the East face. If the collector is running East-West, always prioritize the solar exposure of the South face of the collector.

### 3.4 Collector Site Selection

3.4.1 **Site Selection Tips:** With ideal orientation, solar exposure, and preexisting buried utilities considered, all viable installation locations should be identified by this stage. For an easier installation process, choose one of the viable collector bank locations that require the shortest length of piping. In some cases, increased piping lengths may be required to position the unit in an area of greater solar exposure. Any exposed piping will need the appropriate insulation to avoid impacting the unit's performance.

3.4.2 **Consult an Expert:** Prior to placing a product order, a GLE representative should have worked with you to determine the appropriate size and number of collectors for your needs. If not, please contact your local representative.

### 3.0 Preparation prior to installation

---

Their contact information can be found at <http://www.glesolar.com>, or call (269) 408-8276 for assistance.

### 3.5 Collector Model and Sizing Determination

GLE solar collector products have eight models based on the capacity, height and connection interface. As shown in Table 3.1, products model and sizing information will be introduced in details. The Solar Heater Panel products (SHP) have 4 different models based on the height in foot, seeing 3 foot, 4 foot, 6 foot and 7 foot. Three of these have 10 tubes assembly. Only 6 foot panel has 9 tubes to fit the fence width code (6 foot width) because this model is specifically designed for fence use availability. To make multiple panel connection easily, two different models, End unit and Middle unit (-E/M) are specified. Figures from Fig. 3.3 to Fig. 3.6 are the design diagrams showing the overview and the dimensions of different models and pipe connector. Notice that all panels have identical dimensions only except the height for 3 foot, 4 foot and 7 foot panels. 6 foot unit has 9 tubes.

Table 3.1: Collector Types and Size Information

Collector	Dimensions	Notes
SHP310-E/M	W: 74.25"/1886 mm H: 36.22"/920 mm	18 Gallon, 10 tubes Specialty/Aesthetic Use as railing
SHP410-E/M	W: 74.25"/1886 mm H:47.25"/1200 mm	25 Gallon, 10 tubes Domestic Hot Water
SHP609-E/M	W: 67.60"/1717 mm H: 71.85"/1825 mm	34 Gallon, 9 tubes Domestic Hot Water Use as fence
SHP710-E/M	W: 74.25"/1886 mm H: 79"/2007 mm	45 Gallon, 10 tubes Commercial

### 3.0 Preparation prior to installation

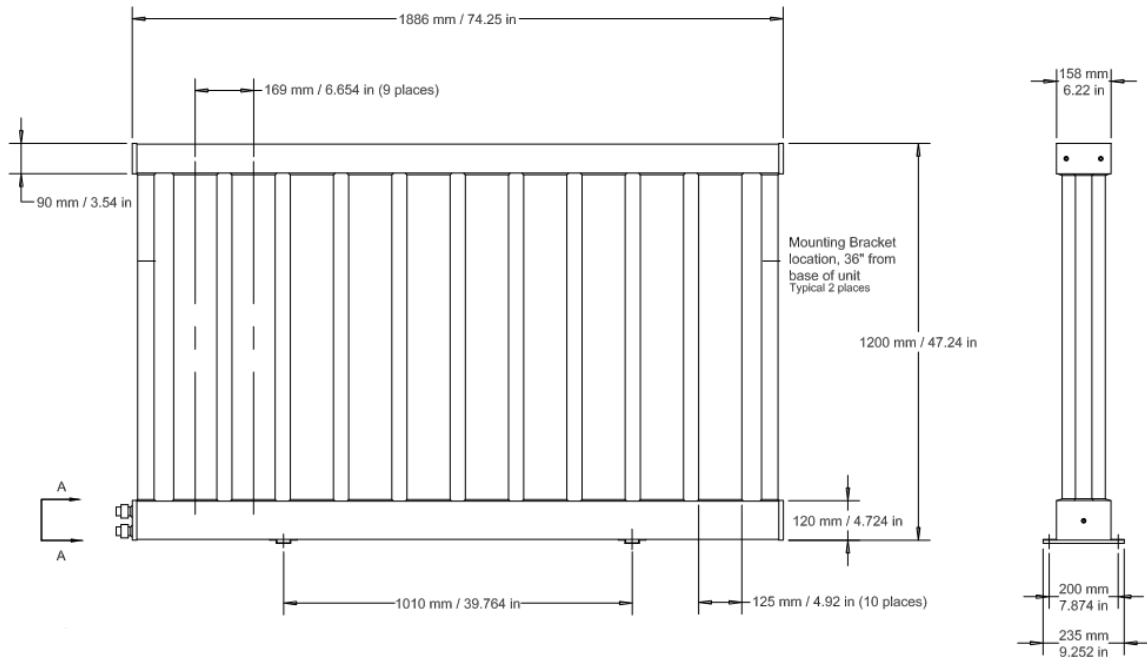

Figure 3.3: SHP410-E unit diagram showing the design and dimensions.

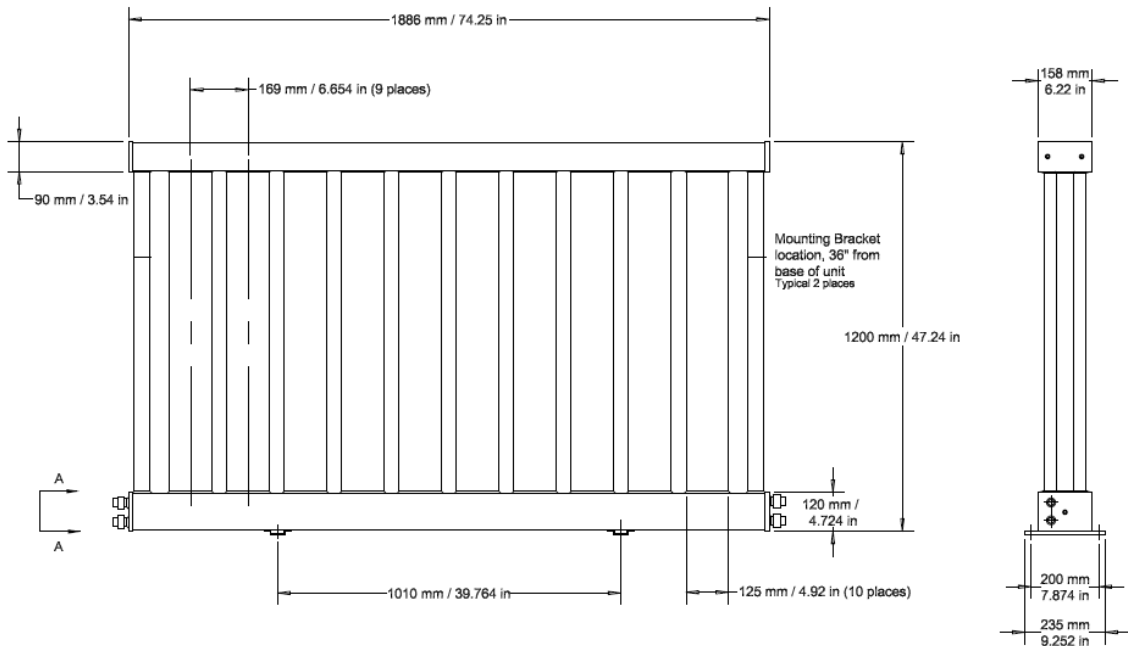

Figure 3.4: SHP410-M unit diagram showing the design and dimensions.

### 3.0 Preparation prior to installation

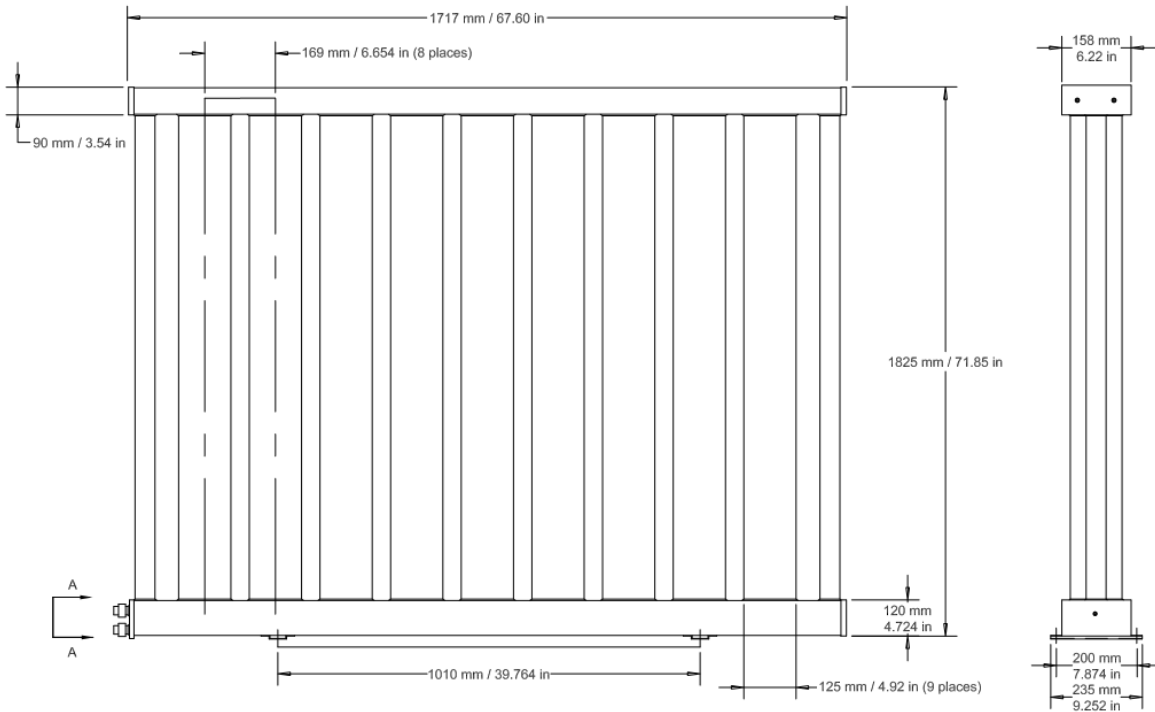

Figure 3.5: SHP609-E unit diagram showing the design and dimensions.

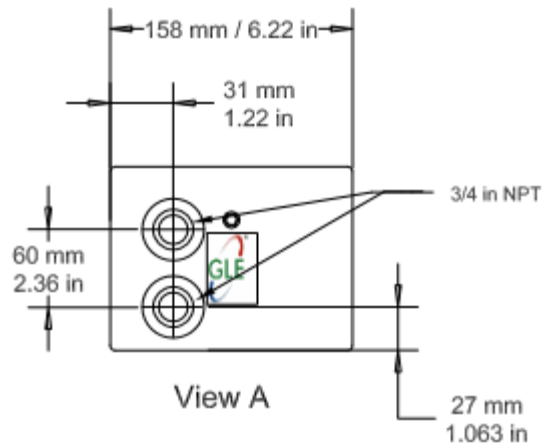

Figure 3.6: Pipe connectors diagram showing the design and dimensions.

### 3.0 Preparation prior to installation

---

- 3.5.1 ***SHP310-E/M***: This panel is 3 foot height, 10 tubes with 18 Gallon storage capacity. SHP310 product is often used for specialty, such as a railing in architecture.
- 3.5.2 ***SHP410-E/M***: This panel is 4 foot height, 10 tubes with 25 Gallon storage capacity. SHP410 is often used for low height fence or barrier to maintain a good view.
- 3.5.3 ***SHP609-EM***: This panel is 6 foot height, 9 tubes with 34 Gallon storage capacity. SHP609 is often used for fence installation.
- 3.5.4 ***SHP710-EM***: This panel is 7 foot height, 10 tubes with 45 Gallon storage capacity. SHP710 is often used for commercial installation.

**Note: Higher panels have a larger rate of performance over cost. Therefore, from the investment payback point of view, buying higher products is recommended if installation allows.**

### 3.6 How Many Panels to Use

Contact a GLE Solar representative to determine the appropriate number of collectors for each specific installation. Accurately sizing a solar thermal collector array depends on a number of variables, ranging from the solar resource of the specific geographic location to the shading of the installation site. However, all system sizing begins with the same list of average daily outputs for domestic hot water applications across the continental United States:

- SHP310: 24,000 BTU/day (capable of heating 50 gallons to 120°F daily)
- SHP410: 32,000 BTU/day (capable of heating 65 gallons to 120°F daily)
- SHP609: 45,000 BTU/day (capable of heating 90 gallons to 120°F daily)
- SHP710: 56,000 BTU/day (capable of heating 110 gallons to 120°F daily)

## Chapter 4.0 Panel Mounting Configurations

Different applications require different configurations in installation. According to the required BTU demand, configuration options and the pros and cons should be taken into account.

### 4.1 Single Panel

In a single panel installation, GLE Solar typically recommends either the SHP410-E or the SHP609-E. Typically for small family DHW supply, such installation is often used to achieve a low installation cost.

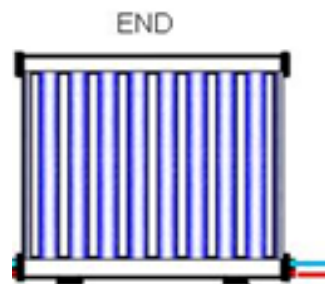

Figure 4.1: Single panel installation by using an end unit.

### 4.2 Multiple Panels

Typical DHW supply or pool heating requires more panels to provide sufficient hot water. How to connect these panels is discussed to satisfy the needs.

4.2.1 **Serial Connection:** The evacuated tube batch collectors are designed for easy connection between multiple collectors in series. However, due to pressure and flow rate concerns, no serial bank of collectors should exceed 4 collector panels, as shown in Fig.4.2.

4.2.2 **Parallel Connection:** If a project requires more than 4 collector panels or greater than 3 GPM system flow, the collectors must be installed in a parallel configuration, as shown in Fig. 4.3.

4.2.3 **Piping Connection Space:** Spacing between collectors in a serial bank consists of the width of a 4x4 mounting post (when treated, the lumber typically condenses to 3.5" x 3.5"). Based on your piping connection need, please consider to have a sufficient space for plumbing connection.

 **Note:** The support posts of the collectors to either side of each mounting post must be securely bracketed to the mounting post to provide stability to the collector bank.

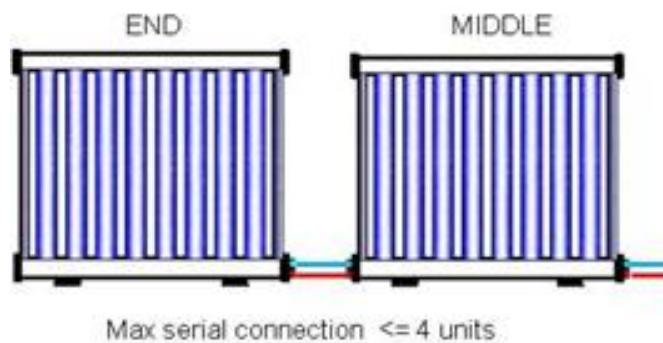

Figure 4.2: Serial connection of multiple panel installation (the maximum number in a serial connection is limited to 4 units).

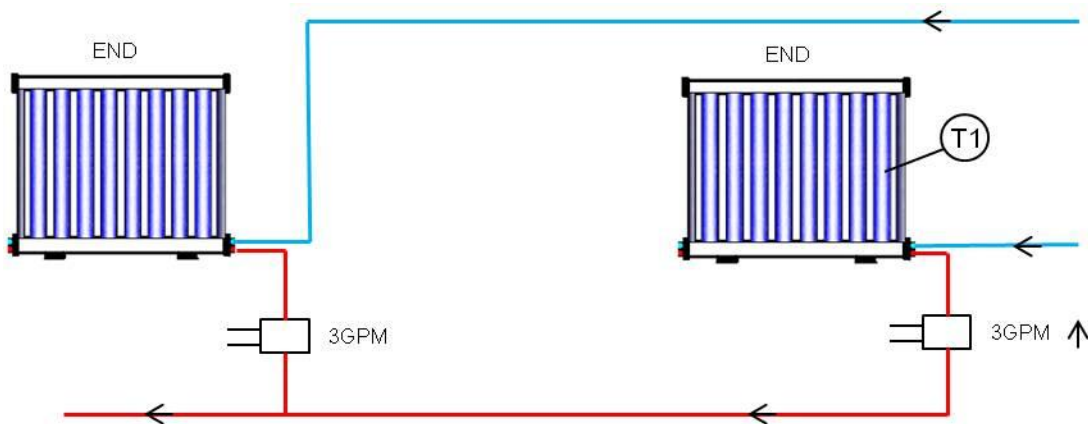

Figure 4.3: Parallel connection of multiple panel installation.



### 4.3 Commercial Array Panel Layout

Most commercial projects require larger quantities of installed collector panels, which will require an array of collector banks involving both series and parallel connections.

4.3.1 **Panel Array:** A combination of serial and parallel connection will be applied in array panels of installation. Collector banks involve up to 4 collectors connected in series, and the collector banks are then connected in parallel. Ideally, all of the collector banks in an array should involve the same number of collector panels, as shown in Fig. 4.4.

4.3.2 **Equal Piping Distance:** Balance the pressure experienced by each collector bank by ensuring that the pipeline leading into each collector bank is identical in length to each of its counterparts. Similarly, ensure that the pipeline exiting each collector bank matches the length of each equivalent outlet pipeline.

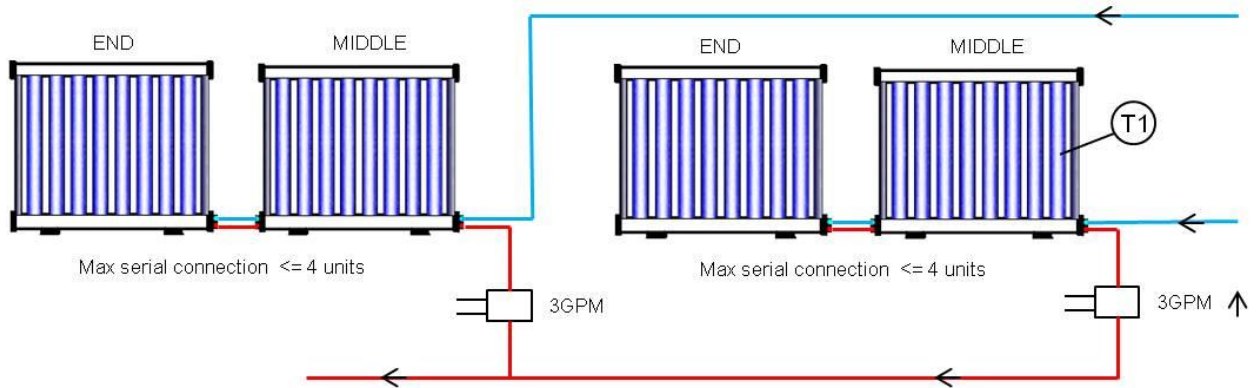

Figure 4.4: Commercial panel array installation showing a combination of serial and parallel connection.

## Chapter 5.0 Collector Panel Installation Process

The collector panel installation process remains the same regardless of the intended application (i.e. domestic hot water, pool, radiant heat, etc.). After completing the installation steps in this section, proceed to the appropriate application installation and operation sections.



**Note: This section does not include the installation of the evacuated glass tubes. DO NOT remove the glass tubes from their packaging at this time.**

### 5.1 Unpacking Collector Main Assembly

- 5.1.1 Prior to opening the packaging containing the collector main assembly, inspect the product for obvious external shipping damage. If the package is damaged, contact your GLE representative immediately. Otherwise, proceed with the installation.
- 5.1.2 Using the appropriate personnel to accommodate the weight, remove the collector from its packaging. Properly dispose of packaging and shipping materials. Reuse or recycle where possible.
- 5.1.3 At this time, inspect the exposed unit for any obvious damage or missing parts. If the unit is damaged or missing parts, contact your GLE Solar representative immediately. Otherwise, proceed with the installation.
- 5.1.4 To remove the top rail, first taking out the 2 screws in each end plate, seeing the Fig. 5.1. Then, identify the plugs on the top surface of the top railing located where the railing joins the steel support post. Remove each plug and disconnect the newly exposed bolt. Finally, remove the mounting brackets attached to the steel support post within the top railing (which holds the end caps in place).

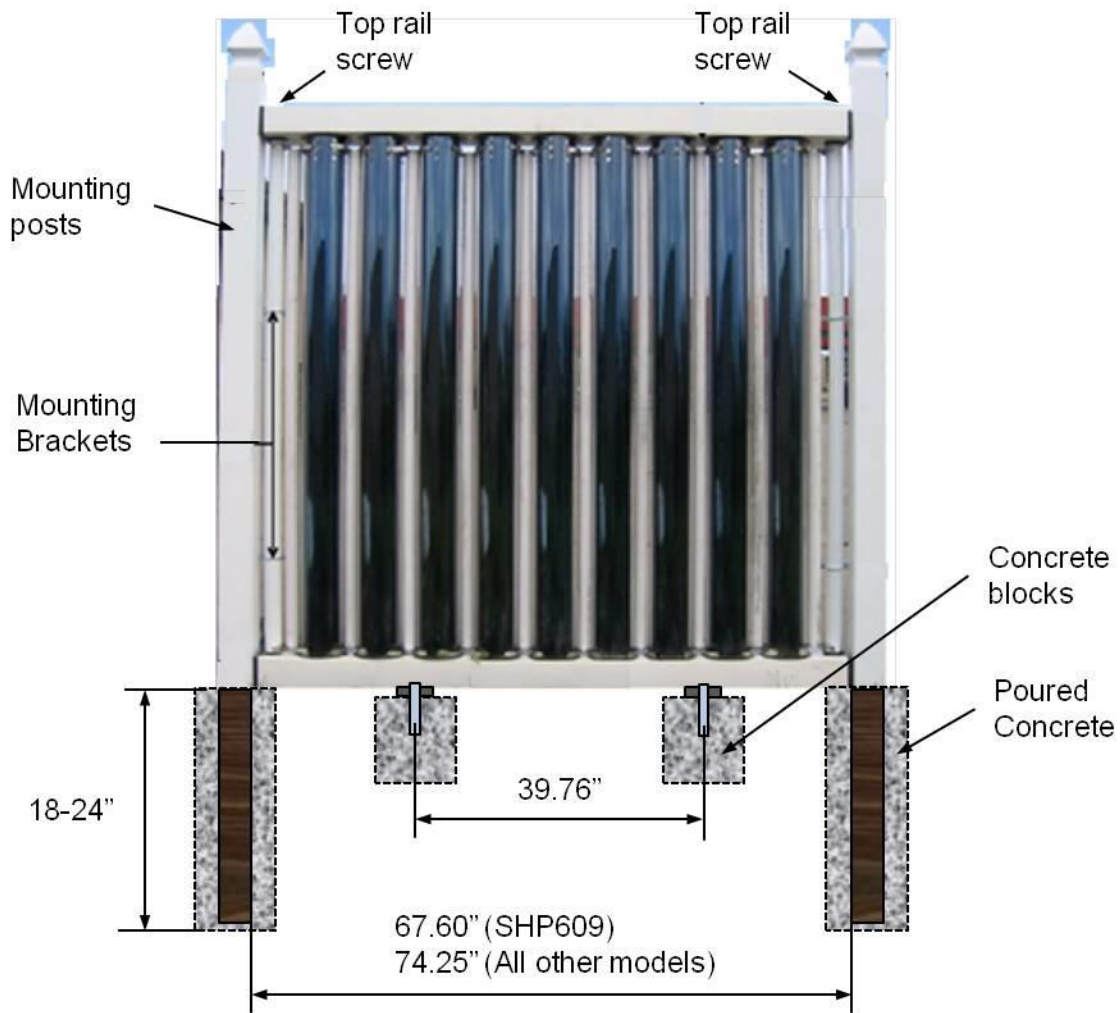

Figure 5.1: GLE Solar water heater fence showing the details for mounting with decorative 4x4 post covers.

## 5.2 Ground Installation

5.2.1 **Foundation:** Refer to Fig. 5.1 for the appropriate dimensions. Identify the precise location where the collector will be installed. Using the appropriate tools, even the grade of the soil so that the collector will rest firmly and evenly on the earth.

Then, locate the two points shown 39.76" apart in Fig. 5.1. These are the center points of the precast concrete blocks that will support the collector's

flared metal feet. Dig two holes such that each concrete block will sit with its top surface even with the surrounding ground. Use the excavated topsoil to pack the holes around the concrete blocks and even out the surface of the installation site.

**5.2.2 *Mounting Posts:*** Use Figure 5.1 to identify the precise location of each 4x4 mounting post. (Alternately, center the collector assembly on the concrete blocks temporarily as a visual aid to mark the mounting post locations.) Using a manual or mechanical boring tool, produce a hole for each mounting post (24" unless a greater depth is required by local or state building codes). Wrap the posts in construction felt or plastic to help extend the life of the post. This will prevent the concrete from decaying the wood at an accelerated rate. Once the post is positioned level in the post hole, pour concrete into post holes and allow it to cure.

**5.2.3 *Securing the Collector:*** Position the collector assembly in the space created for it, with the assembly feet resting in the center of the concrete blocks and the assembly support posts in close proximity to the secured vertical mounting posts. Use an anchor bolt on either side of each flared collector foot to affix the foot to the concrete block base.

Then, remove the 4 support post brackets from their packaging. The metal loop hooks around the collector assembly support post, and the flat bracket portion is secured to the mounting post. One bracket must be installed on each support post 12 inches above the ground and another bracket must be installed at the halfway point between the first bracket and the top of the collector assembly.

 **Warning:** The unit must be secured at the top and at the bottom for proper installation! Failure to do so could cause personal injury or property damage and will void the warranty.

## Chapter 6.0 Pool Heating System Design

GLE Solar panels can be used for heating swimming pools as long as the pool water does not pass directly through the collector bank. This section describes how to establish a solar heating loop separate from the existing pool filtration loop and join them with an external heat exchanger.

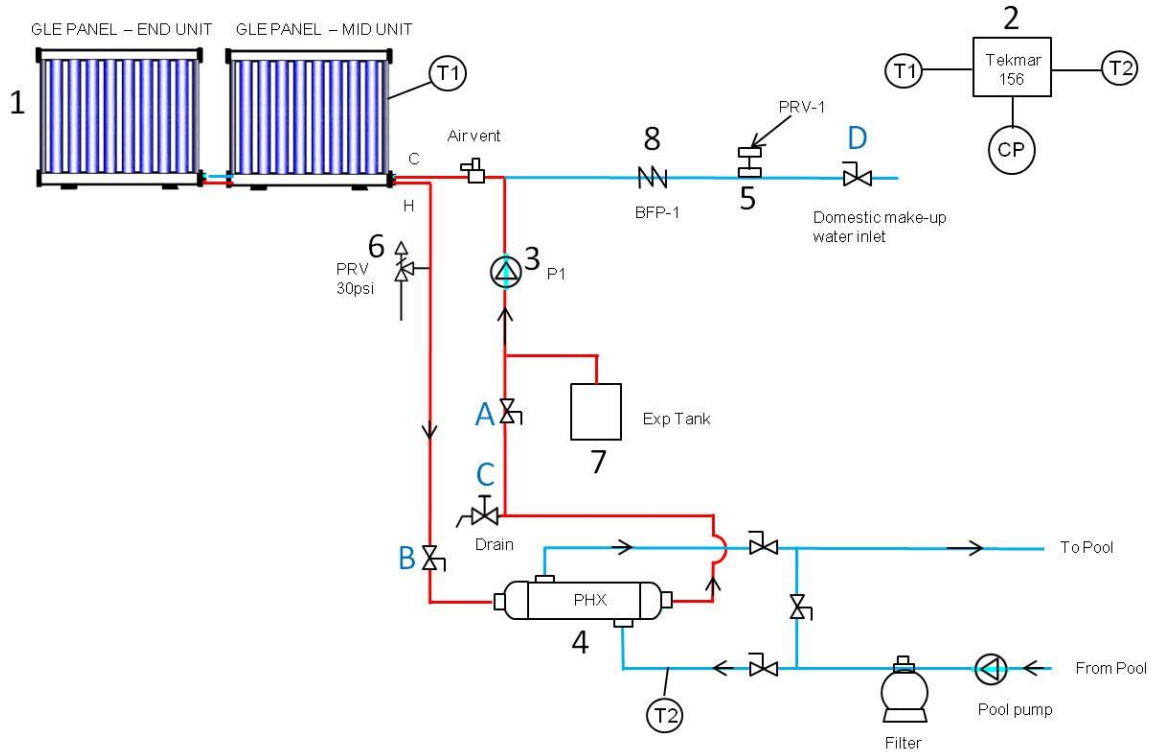

Figure 6.1: Basic pool system design diagram showing basic functionality.

Table 6.1: Pool System Key Parts List

Order	Name	Description	Sizes
1	Solar collectors	GLE Solar ICS collectors	4 foot; 6 foot panel
2	Controller	Tekmar 156	
3	Circulation pump P1	Grundfos UPS15-58FC	5.5 gpm
4	Heat exchanger	Titanium or stainless steel SP-300K	70 gpm
5	Pressure reducing valve (PRV-1)	Apollo/Conbraco 36C204G2	Set 15 psi
6	Pressure relief valve (PRV)	Apollo/Conbraco RVW 10	30 Psi
7	Expansion tank	Amtrol ST-12	4.4 Gallon
8	Backflow Prevention (BFP- 1)	Apollo/Conbraco, DCAP	1 / 2"
9	Pipe for solar loop	PEX	
10	Pool loop	PVC	

## 6.1 Basic System Details

- The pool loop will vary dramatically from system to system, but the installation should always follow the basic guideline of positioning the heat exchanger after the filtration system and before any auxiliary heating source.
- The collector thermistor wire (or the thermistor wire from the final collector in series) is temperature sensor T1. The temperature sensor that arrives with the Tekmar 156 is temperature sensor T2, and it must be strapped to the outside of the hose clamp on the pool loop piping entering the heat exchanger. This functions as a measurement of the pool water temperature. Insulate around the piping for a proper reading.
- A 30 PSI pressure relief valve must be positioned on the piping exiting the collector bank hot water outlet. While additional isolation valves can be installed in individual systems, never install an isolation valve between the collector bank and the pressure relief valve.
- For chlorinated pools, use a stainless steel heat exchanger. For saltwater pools, use a titanium heat exchanger.

## 6.2 Pipe Materials and Installation

GLE Solar approves the use of the following materials for the solar loop piping.

6.2.1 **Above Ground Piping:** The following options are all acceptable, and they have been listed in order of GLE Solar's preference:

- Type L copper pipe with wrought copper "sweat" fittings
- Type L copper pipe with mechanical fittings (Example: SharkBite)
- Corrugated T316 stainless steel pipe (Examples: SolarTrac or OmniFlex)
- PEX Oxygen Barrier piping using mechanical crimp fittings (Example: Rifeng)
- PEX Oxygen Barrier piping with mechanical fittings (Example: SharkBite)

6.2.2 **Below Ground Piping:** For all underground piping, use RhinoFlex or an equivalent pre-insulated piping

6.2.3 **Pipe Sizing:** Use pipe sizing charts provided by the piping manufacturer based on the material selected. Pipe velocity shall not exceed 2 feet per second.

6.2.4 **Planning the Pipe Route:** First, determine whether the piping between the collector and the heat exchanger will need to be above ground or underground. Once the route is determined, make note of the high point in the system elevation and install an auto air vent (Watts FV-4M1 or equivalent). The location of the air vent in the diagram does not reflect actual project conditions, so adjust to individual jobsite conditions.

6.2.5 **Pipe Supports and Hangers:** Properly support all piping with support structures and hangers as applicable to the material selected and in accordance with local, state, and federal code.

### 6.3 Component Locations and Details

- 6.3.1 **Pump & Controller:** Locate the pump and controller in a suitable dry space away precipitation that is incompatible with both line and low voltage wiring, control, and enclosures.
- 6.3.2 **Heat Exchanger:** Locate the heat exchanger in the same housing as the pool pump and filter. This will minimize the additional pool loop piping lengths and limit piping heat loss. Provide isolation valves and a bypass line to allow the user to bypass the heat exchanger during times of pool shocking (superchlorination), backwash, and rinse cycles.
- 6.3.3 **Make-up Water Source:** Connect the solar loop to the fresh water supply through an approved backflow prevention device (Watts BBFP or equivalent). Adjust to local and state code as needed to protect against contamination of the domestic water supply. A check valve is not an approved means of backflow prevention, so do not apply a swing or spring check valve between the domestic water feed line and the solar loop.



**Note:** Do not connect the power to the controller at this time. Wait until the manual indicates it is time for system startup.



## Chapter 7.0 Pool System Operation

### 7.1 General Operation and System Startup

Some principle points must be understood to safely operate the solar water heating systems. Please pay attention to the following details.

- 7.1.1 **Water pressure limits:** GLE panels are capable of withstanding up to 160 psi of sustained pressure, but the systems should not exceed an operating pressure of 80 psi.
- 7.1.2 **Water temperature limits:** When stagnant, the contents of collectors exposed to sunlight can eventually exceed 100°C (212°F). During system operation, the water in the collector should never exceed 180°F.
- 7.1.3 **Pool operation:** Do not start up the solar loop until the pool is already filled and operational for the season. The filtration system must operational and cycle regularly for the system design. If the filtration strategy is irregular, wait to fill and activate the solar loop until discussing the situation with a GLE Solar representative.
- 7.1.4 **Collector water temperature sensor:** The thermistor located in each panel is positioned in the water reservoir beneath the last tube in the flow progression. The thermistor reaches 18 inches from the bottom of the reservoir.

### 7.2 Setting System Parameters

After the system is installed, allow a half day of direct sunlight to begin the warming process before setting the controller to start regular water flow. Program the following setting into the Tekmar 156 controller.

- Setpoint  $\Delta T$ : 50°F
- Differential  $\Delta T$ : 40°F
- Source Minimum Setpoint: 90°F
- Source Minimum Differential: 5°F
- Storage Maximum Setpoint: 105°

### 7.3 System Filling

In colder climates where the solar loop will remain in use through times with freezing temperatures expected, install a solution of clear fresh water and propylene glycol. GLE Solar suggests the use of Dynalene PG glycol for low temperature applications.

7.3.1 ***Glycol mixture for freezing climates:*** Due to varying geographic installation locations, the installing contractor is responsible for identifying the lowest possible temperature to be experienced for the particular installation location and provide an appropriate mixture of Fresh Water & Propylene Glycol.

Utilize the concentration chart provided at [www.dynalene.com](http://www.dynalene.com) to determine the appropriate concentration for low temperature thresholds.

7.3.2 ***Glycol mixture rates:*** As a general guideline, use Table 7.1 to estimate PG Glycol volume for each unique system to provide “burst” protection.

For installations involving multiple collector panels, the total volume is the sum of all panels’ capacity.

Table 7.1: Glycol mixture rates at each low temperature range

Ambient temperature °F	Volume % Dyanlene PG For Burst Protection
-30	33%
-20	30%
-10	27%
0	24%
10	20%
20	12%
> 32	0%

**Filling process:** All plumbing components should be installed in accordance with the system diagram prior to the glycol filling process, including the valves to fill glycol and clear water separately.

Typically these are the valves to be used for filling glycol:

- Valve A: Hot port connection outlet valve
- Valve B: Cold port connection inlet valve
- Valve C: Fill valve for glycol
- Valve D: Fresh water filling connection valve

When these valves and all loop pipelines are appropriately installed, follow the steps to complete the filling as below.

Step 1: Calculate the glycol volume based on the panel units in the project. Prepare a drum of glycol with the quantity calculated.

Step 2: Confirm that valves A, B, and Care open to begin the process. Only valve D should be closed at this time.

Step 3: Set up a transfer pump (Wayne PC4 or equivalent). Connect a garden hose to the pump inlet and place the other end of the hose in the glycol drum.

Step 4: Connect a garden hose from the pump discharge outlet to drain valve C.

## 7.0 Domestic Hot Water System Operation

---

- Step 5: Start the transfer pump to begin filling the system with propylene glycol. Proceed until the drum of supplied glycol has emptied into the system, and deactivate the pump. Repeat the process as needed if multiple drums of glycol are required.
- Step 6: With the total calculated glycol volume transferred into the system, close valves B and C and remove the hose from valve C.
- Step 7: Open valve D and begin to fill the system. Allow the auto air vent to purge the air from the piping.
- Step 8: When the auto air vent stops purging gas, open valve B and turn on the circulation pump manually to allow fluid to circulate. The auto air vent will purge the remaining system air. This could take an hour or so to finally purge.

## Chapter 8.0 Glass Tube Installation

When all the pipelines and control connections are completed, it is finally time to proceed with the installation of the evacuated glass tubes.

### 8.1 Unpack Glass Collector Tubes

- Carefully remove tubes from shipping containers. Only remove one tube at a time to prevent tube heating prior to handling.
- Once all tubes are removed from each box, the cardboard and Styrofoam packaging may be properly discarded.
- Remove top rail from collector base by removing 4 screws from each end as shown in Fig. 5.1.

### 8.2 Individual Placement of Tubes

8.2.1 **Install tubes:** This step requires heavy lifting, so confirm there are enough participants in advance. Apply a black seal to the bottom end of each tube, approximately  $\frac{1}{4}$ " from the end. Slide each glass tube onto a separate stainless steel tube, being careful not to scratch the inside of the glass tube while lowering slowly into place. Repeat until all tubes are in place.

8.2.2 **Install rubber seal:** Apply upper rubber seal to glass tube.

8.2.3 **Put up-rail back:** Once tubes are in place, replace top rail. Replace all bolts/screws that were originally removed except the bolt in the end cap that is on the opposite side of the plumbing fittings. This is to make future maintenance access easier.

### 8.3 Completion of Installation

Repeat steps 8.1.1 through 8.2.3 for each panel.

## Chapter 9.0 Maintenance and Service

Due to varying geographic installation locations as well as climate conditions, certain considerations for maintenance and service may be required to maintain proper operation.

### 9.1 Maintenance

Maintenance and service are needed periodically, which is easily carried out due to the ground installation. Some situations are described as below.

- 9.1.1 **Overall system:** All system components that require periodic attention are easily accessible. Due to the lack of moving parts and the stainless steel components, GLE Solar collectors do not require regular maintenance. For all other system components, consult the manufacturer documents for maintenance information.
- 9.1.2 **Glass tube surface cleaning:** If the evacuated tubes begin collecting a layer of dirt and grime, the absorption potential of the tubes decreases. Use a soft cloth to apply a warm solution of water and soap.
- 9.1.3 **Broken glass tube:** If evacuated tubes are damaged, carefully clean up any glass fragments and contact your local GLE representative to replace the tube(s). If the damage occurs when outside temperatures reach below freezing, do your best to provide extra temporary insulation around the exposed metal reservoir until the tube is replaced, as an added precaution.
- 9.1.4 **Report as needed:** If visible damage occurs to the rubber seals at the base of each tube or the unit appears to be leaking or any others, contact your local GLE representative immediately.

## 9.2 Special Considerations

For some extreme heating conditions, special considerations are taken into account to keep products protected and free from possible damage.

- 9.2.1 **Cover tubes when over capacity:** During the summer months, the higher solar resource may produce hot water in excess of your needs. One or more tubes can be covered with GLE tube covers (or any opaque, non-abrasive material, such as canvas) to reduce the output for the remainder of the season.
- 9.2.2 **Cover tubes when unused:** If the system will certainly not be used for 3-14 days, set the controller to circulate continuously until you return. If the system will sit unused for longer than two weeks, consider covering the tubes if filled with glycol or its mixture in cold weather or simply covering the tubes in warm weather.
- 9.2.3 **Power outage:** If the system loses power during warm weather, a pressure relief valve will empty the solar loop. Do not obstruct the drainage path of this relief valve, and do not interfere with the emergency drainage, as the loop contents could be hot enough to cause injury.

### 9.3 System Shutdown

When the system will not be used for a long time or the collector loop requires service, the system must be shutdown. To avoid mistakes that could damage the system and void the collector warranty, follow these steps precisely to achieve proper system shutdown:

9.3.1 **System draining out.** Drain the water or glycol mixture from the collector through the following steps.

Step 1: Adjust the ball valves to isolate the collector loop.

Step 2: Connect an air compressor to the hot water outlet end of the collector (or collector bank). Open the drain valve, and apply 40 psi until the heat transfer fluid is completely purged.

Step 3: Keep the drain valve opened after the collector loop is emptied.

9.3.2 **Cover collectors totally.** Use a cover to block the tube surfaces from absorbing solar energy. The cover strategy can involve directly surrounding each individual tube with a fabric cover, which can be anything nonabrasive and capable of blocking all solar energy, including ultraviolet (canvas is a reasonable option). An alternative cover strategy involves covering the entire collector surface with plywood boards (picture a French door configuration). When anchoring the plywood, do not pierce or modify any component of the collector assembly or apply any force to the evacuated glass tubes.



**Note:** The evacuated solar collector tubes generate very high temperatures whether or not the system is in use. If the tubes are not covered after draining the system, the conditions put the system under what is called a thermal shock load, which will damage the system permanently. This will void the manufacturer warranty.